

Hygiene & Maintenance

# iClave



**NSK**

# The Comfort You Wanted

Sterilising dental instruments is crucial for patients' and operators' safety. The new iClave autoclave perfectly combines performance, user experience, and technology, ensuring an effective, comfortable, and worry-free experience.

Its stainless steel chamber, with 5 trays of 2 different dimensions, maximises the actual capacity. In addition, the new high-efficiency steam generator allows for superior performance, resulting in perfectly sterilised equipment in less time.

But there's more. The user-friendly iClave colour touchscreen, elegant, ergonomic design, and cutting-edge technology make it a safe, efficient device that is also a pleasure to use.

NSK's unmistakable quality and reliability ensures impeccable sterilisation, making an iClave the effective and comfortable answer to your needs.

## The new iClave





# YOUR NEW COMFORT IS A MATTER OF PERFORMANCE

## Optimised load capacity

Not all autoclaves are the same. The 24-liter version of iClave has an actual capacity of up to 7 kg – taking it to the top of its category. Its 5-tray system, allows you to exploit all the room inside the chamber.

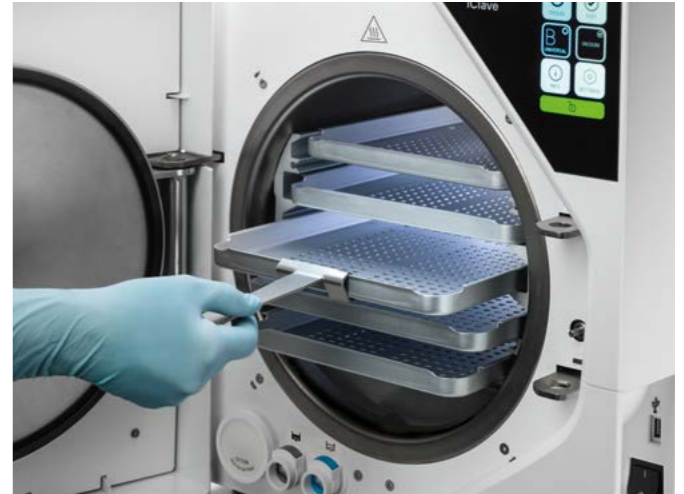

## Fast cycles, excellent performance

Every detail has been designed to guarantee efficient, reliable performance: the new high-efficiency steam generator with stainless steel coil injects the steam into the chamber, into the middle of the tray holders, which act as heat accumulators, enabling a more even distribution of heat and lessening its impact on the instruments. The heat accumulated by the tray holders is released to the load during the drying phases, guaranteeing perfect, rapid drying. Together with the design of the chamber, the trays and the water circuit, this system enables rapid Class B and Class S cycles.

\*Typical load: 2 kg.

iClave 18 iClave 24

Class	iClave 18	iClave 24
Class B Univ	38 mins	47 mins
Class B Fast	23 mins	29 mins
Class S Fast	22 mins	32 mins

## Internal ventilation: quiet and efficient

The internal ventilation system is effective and durable. It is also a very quiet ventilation system, which translates into long-lasting performance and more comfort for the operator.



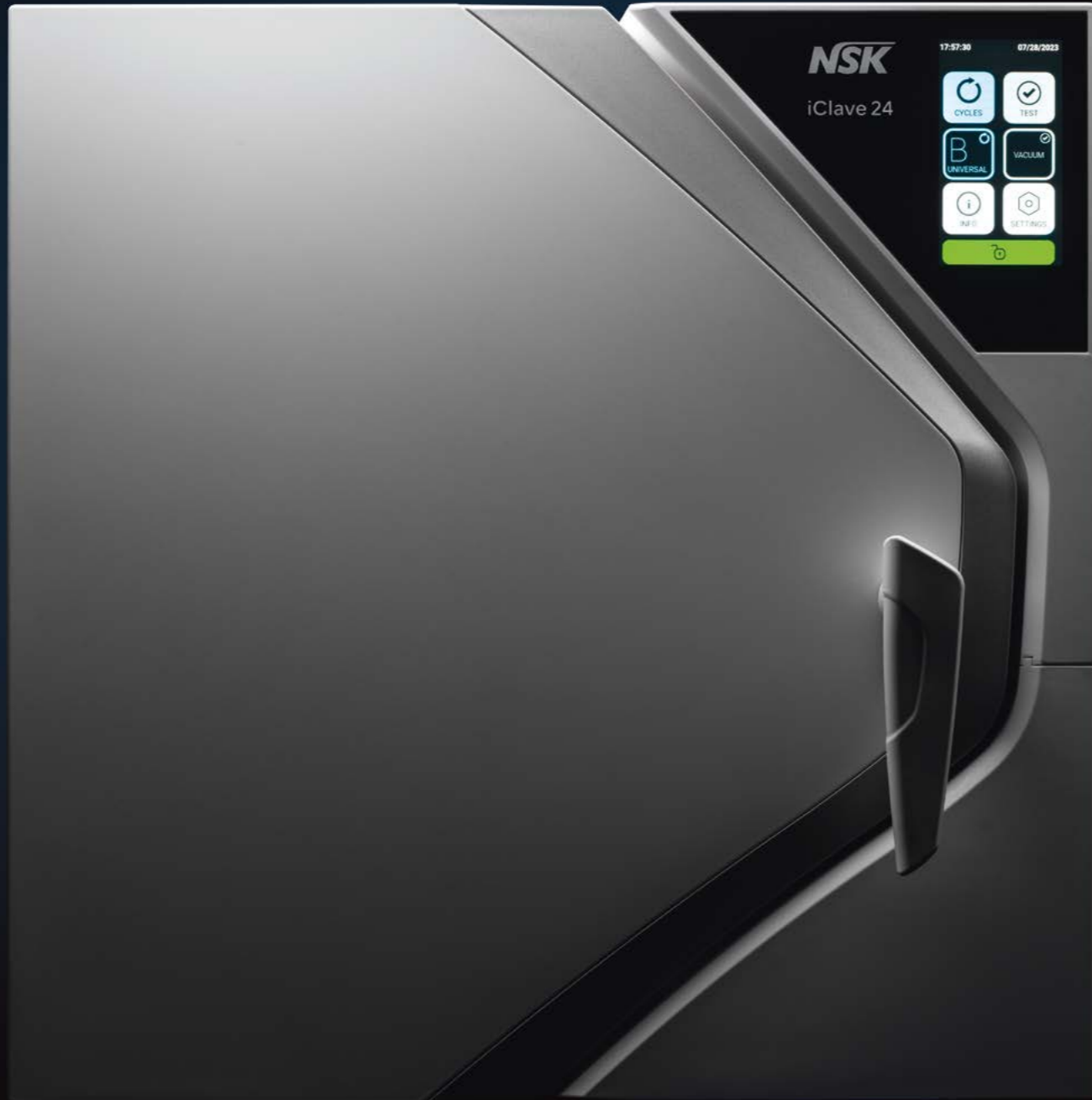

## YOUR NEW COMFORT IS A MATTER OF USER EXPERIENCE



### A next-generation experience

Nowadays, we are all used to interacting with various devices every day.

The iClave's 4.3" capacitive colour touchscreen is extremely straightforward, and can even be used while wearing gloves. This way, managing every function – from programming cycles to running tests – is a safe and satisfying experience, ensuring perfect sterilisation.

### A faster, safer, and more practical way to manage water

Filling and emptying the water tank are some of the operations that impact the user's comfort and safety. The iClave's chemical-resistant clean water tank is easy to fill and clean. It also has a filter you can easily remove and replace.

In addition, the two quick connectors for used water and clean water drainage respectively ensure these operations can be handled safely and extremely practically, because the water can only drain away if the tube is inserted into the connector, making the operation extremely user-friendly.



### Ergonomic down to the tiniest detail

An ergonomic design is essential to work comfortably and effectively. Every detail and every function of the iClave is designed to meet this need: the design of the interior (chamber and tray system), how the autoclave is easy to open for cleaning and maintenance, and the capacitive touchscreen. Everything works towards the same goal: maximum comfort for the operator.



## YOUR NEW COMFORT IS A MATTER OF TECHNOLOGY

### Ethernet connection for advanced data management

A contemporary autoclave must ensure safe sterilisation cycles and be able to track and store all the data. The iClave meets this need in more than one way. First of all, through an Ethernet connection that allows you to connect the autoclave to a web platform making storing and analysing data a breeze.



### Easy, worry-free traceability thanks to the built-in or external printer

Tracking the sterilisation data of every load and every instrument allows dentists and their teams to safely store them ready for use, knowing exactly when they were sterilised. The iClave's built-in or external printer meet this requirement by printing reports and labels, thus boosting safety, for the peace of mind of both dentist and patient.



### Store data wherever you want with a USB flash drive

Another way to store sterilisation and periodic test data is by using a USB flash drive, which allows you to transfer all the information from the autoclave to a computer and save it wherever you want.



Built-in printer

External printer

# TECHNICAL DATA

## Sterilisation cycles

iClave is a steam steriliser for materials and medical devices that are likely to come into contact with blood and body fluids. Based on the requirements of the EN 13060 standard for small sterilisers, it is suitable for the following sterilisation cycles and loads:

**Class B** Sterilisation of wrapped and unwrapped solid, porous, and hollow instruments, as represented by the test loads in the standard. **Class S** Sterilisation of unwrapped solid products.

CYCLE	TEMPERATURE	STERILISATION	DRYING TIME	TYPICAL LOAD	TYPICAL LOAD CYCLE TIME	MAX LOAD	MAX LOAD CYCLE TIME
<b>B Universal</b>	134°C	4' 00"	10'	2 kg	38' (iClave 18) 41' (iClave 24)	5 kg (iClave 18) 7 kg (iClave 24)	51' (iClave 18) 59' (iClave 24)
<b>B Prion</b>	134°C	18' 30"	14'	2 kg	59' (iClave 18) 62' (iClave 24)	5 kg (iClave 18) 7 kg (iClave 24)	72' (iClave 18) 78' (iClave 24)
<b>B Fast</b>	134°C	3' 30"	5'	-	-	0.5 kg (iClave 18) 0.7 kg (iClave 24) *	23' (iClave 18) 29' (iClave 24)
<b>B 121</b>	121°C	20' 30"	16'	2 kg	61' (iClave 18) 67' (iClave 24)	5 kg (iClave 18) 7 kg (iClave 24)	76' (iClave 18) 82' (iClave 24)
<b>S Fast</b>	134°C	3' 30"	7'	-	-	1 kg (iClave 18) 2 kg (iClave 24)	22' (iClave 18) 32' (iClave 24)

\* Use only one tray in the second slot, starting from the bottom. Only for solids, hollow wrapped and unwrapped.

## Technical features

### iClave 18

OVERALL DIMENSIONS	451 x 492 x 669 mm (L x H x D)
CHAMBER DIMENSIONS	Ø 265 - 368 mm (D)
CHAMBER CAPACITY	18 L
LOADLESS WEIGHT	52 kg
SUPPLY VOLTAGE	230 V ~ 50/60Hz
POWER CONSUMPTION	10A - 2300 W
CYCLE WATER CONSUMPTION**	700 ~ 800 cc
TANK CAPACITY (clean and used water)	5 litres each
SOUND LEVEL	60 dB(A)

### iClave 24

OVERALL DIMENSIONS	451 x 492 x 669 mm (L x H x D)
CHAMBER DIMENSIONS	Ø 265 - 475 mm (D)
CHAMBER CAPACITY	24 L
LOADLESS WEIGHT	55 kg
SUPPLY VOLTAGE	230 V ~ 50/60Hz
POWER CONSUMPTION	10A - 2300 W
CYCLE WATER CONSUMPTION**	700 ~ 800 cc
TANK CAPACITY (clean and used water)	5 litres each
SOUND LEVEL	60 dB(A)

\*\* Water consumption varies depending on device operating conditions (e.g. chamber temperature, cycle selected, etc.).

SAFETY FEATURES	Blackout protection • Short-circuit protection • Overheating protection • Overpressure protection • Accidental door opening protection • Process evaluation system • Real-time troubleshooting system • Adaptive Heat system
CERTIFICATIONS	• Class IIb medical device compliant with Regulation (EU) 2017/745 on medical devices (MDR) (Article 16) • Chamber compliant with Directive 2014/68/EU • Company: ISO 9001 - ISO 13485
COMPLIANCE International standards	EN 13060 • IEC 61010-1 • IEC 61010-2-040 • IEC 61326-1 • EN 13445

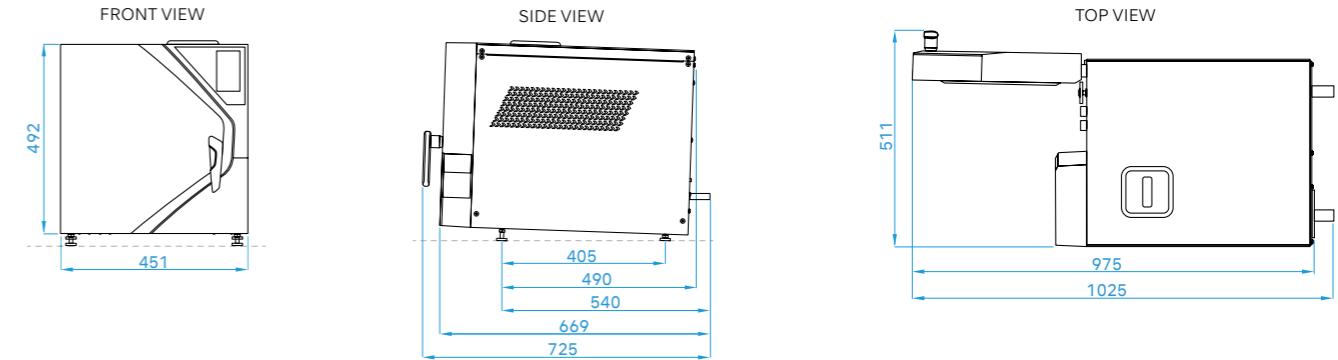

## LINE UP

MODEL **iClave 18**  
(excluding printer)  
CODE **91812B0100**

MODEL **iClave 18**  
(including printer)  
CODE **91812B0100P**

MODEL **iClave 24**  
(excluding printer)  
CODE **92412B0100**

MODEL **iClave 24**  
(including printer)  
CODE **92412B0100P**



0051



All iClaves are also available with an UK plug

## RELATED PRODUCTS

**Printer**  
(optional extra)  
CODE **9900009**

Affordable and compact optional external printer, ideal for printing sterilisation data on paper or labels. Equipped with a USB cable and a power supply.



**Helix Test**  
CODE **9900059**

Allows you to verify steam penetration into hollow instruments. This test kit consists of a plastic tube with an indicator strip housing on one end and is supplied with 250 easy-to-read test strips compliant with the EN 867-5 standard.



**Demin30 Kit**  
CODE **98001000**

Mixed bed and ion exchange resin system for the complete demineralization of the water.

Easy to install on various autoclave models, offering optimal performance and protection of sterilised instruments, extending the life of autoclaves or other reprocessing devices.

The demineralization system is also available in a version compliant with EN 1717 (code 98001010).



Create it 